

Specification Sheet



M/Flex

Model Number: MF22S88C12

List Price (As of 04/02/16): \$765.00

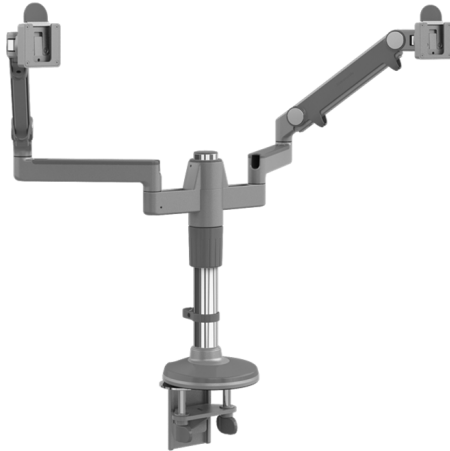

FEATURES

- Supports up to six monitors from a single post
- Supports up to twelve monitors from two posts connected via crossbars
- Utilizes Humanscale's award-winning [M2](#) and [M8](#) Monitor Arms
- In-field reconfigurations achieved without disruption to existing equipment
- Unmatched configuration options
- M/Flex with M2 arm: 15-years, 24/7 warranty
- M/Flex with M8 arm: 10 years, 24/7 warranty

SPECIFICATIONS

- Mounting options can be Surface, Vertical and Custom solutions
- Additions can be made to the post(s) without disturbing the original configuration
- Five total post heights
- Can accommodate one or two rows
- Users can choose to have up to three monitors per row
- Nesting, integrated bracket design allows for easy add-ons
- Single bracket easily converts to double bracket
- Double bracket can also convert to triple bracket
- M2 arm option supports any monitor weighing 8-20 lbs
M2 Light arm option supports any monitor weighing 4-14 lbs
M8 arm option supports any monitor weighing 8-40 lbs
- Additions can be made without removing existing brackets or installations

CONFIGURATION DETAILS

CODE DESCRIPTION

MF2	- M/Flex for M2 Arms
2	- Bracket for 2nd Monitor
S	- Silver with Gray Trim
8	- 12" Straight Link/Dynamic Link
8	- 12" Straight Link/Dynamic Link
C	- Clamp Mount
12	- 12" High Post
-	Standard 100mm x 100mm (also 75mm x 75mm)

SUSTAINABILITY

A selection of sustainability highlights for the M/Flex:

- Recycled content: 12% post-consumer, 5% pre-consumer
- Made predominantly of steel and aluminum, which are highly recyclable
- Shipped in packaging that contains recycled content

FIND OUT MORE

Humanscale.com